

FOX 6

Edwin
Corrie

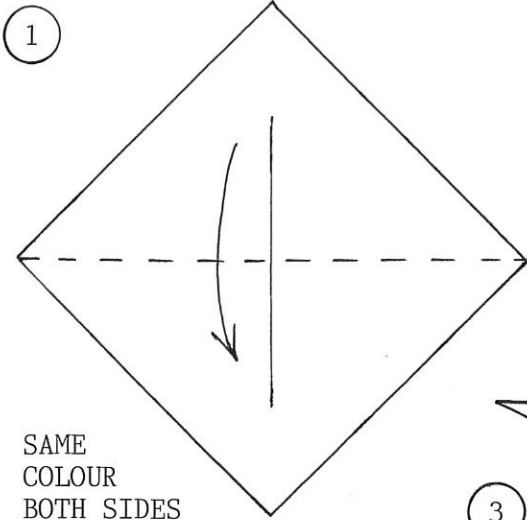

SAME
COLOUR
BOTH SIDES

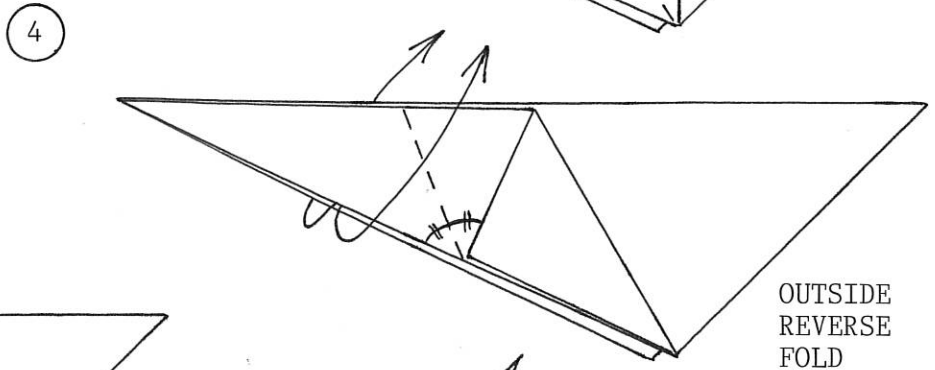
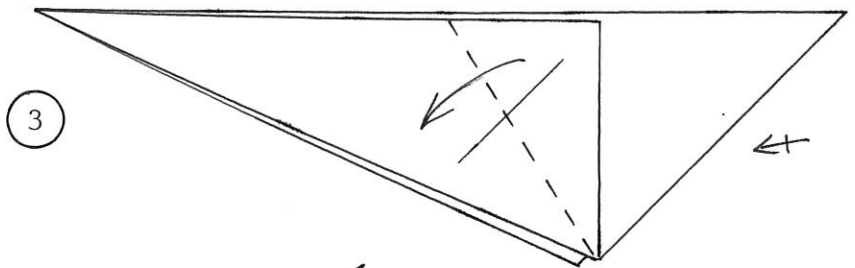
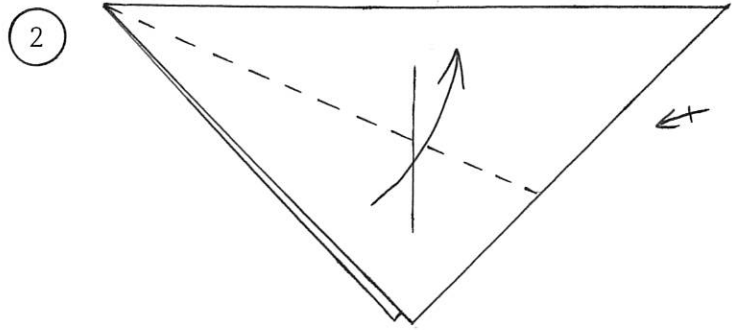

OUTSIDE
REVERSE
FOLD

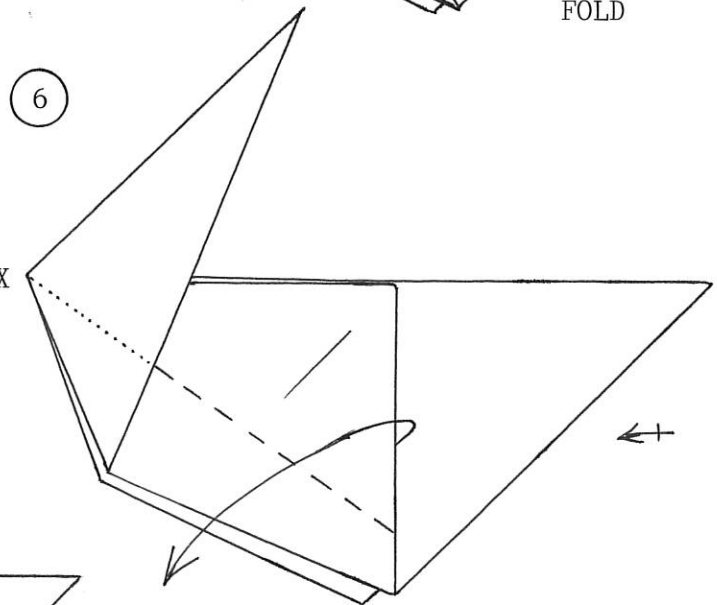
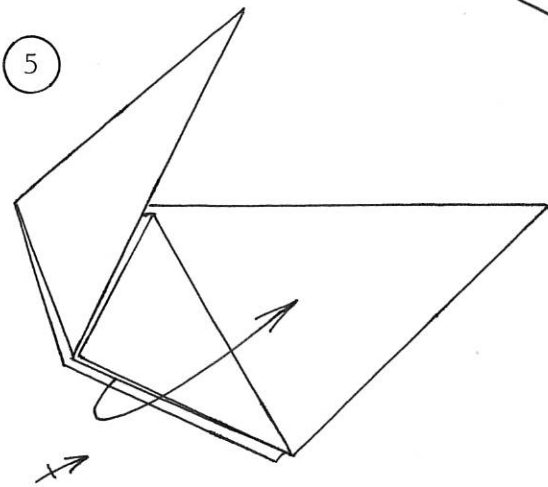

FOLD DOWN, BISECTING
THE ANGLE AT "X".

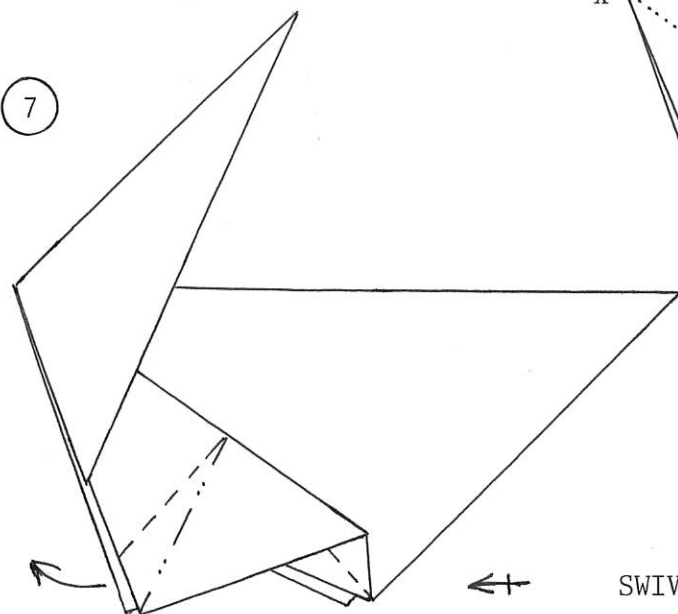

SWIVEL FOLD

8

MATCH UP THE TWO EDGES AS SHOWN

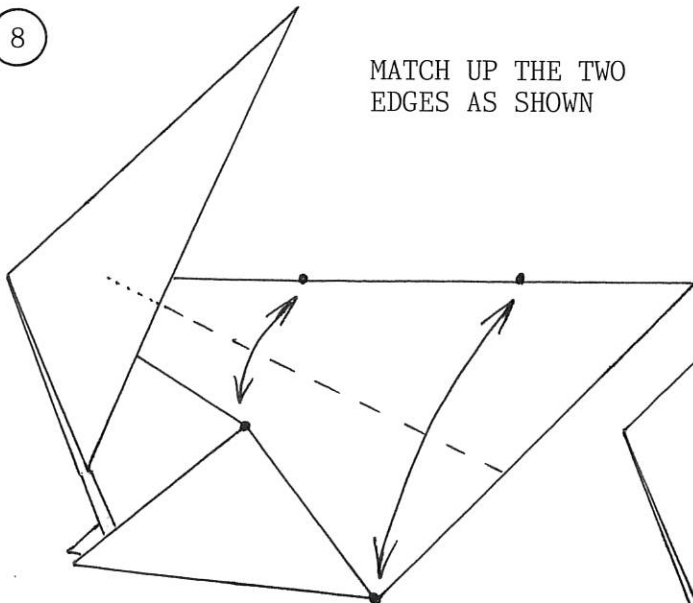

9

INSIDE REVERSE FOLD

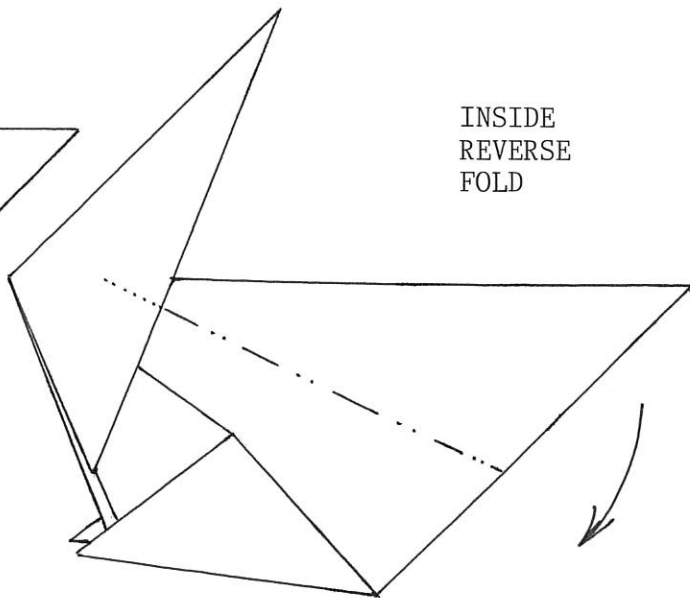

10

MATCH UP EDGES

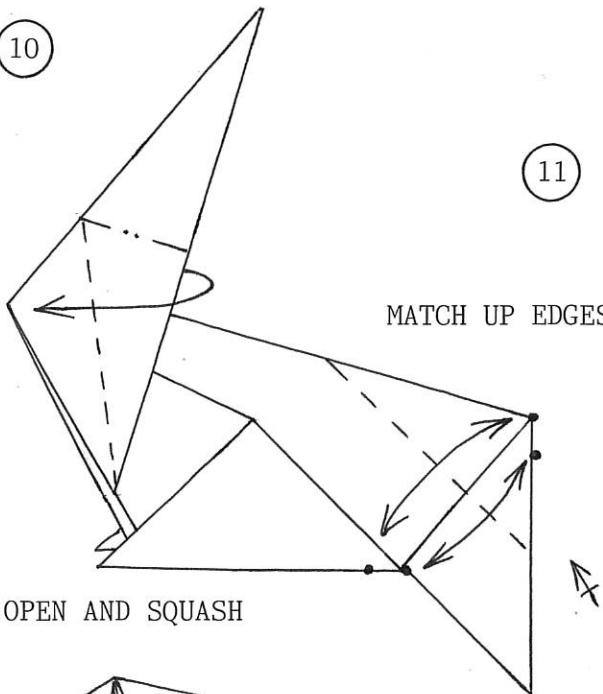

OPEN AND SQUASH

11

SWIVEL FOLD

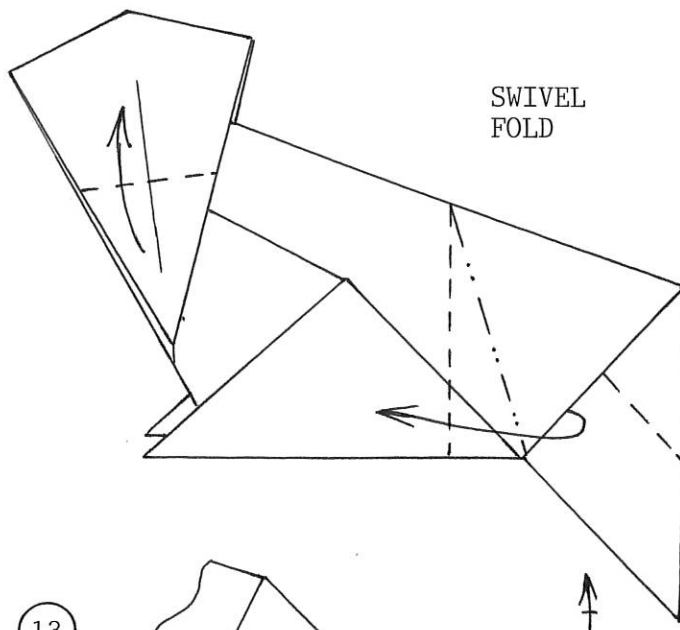

12

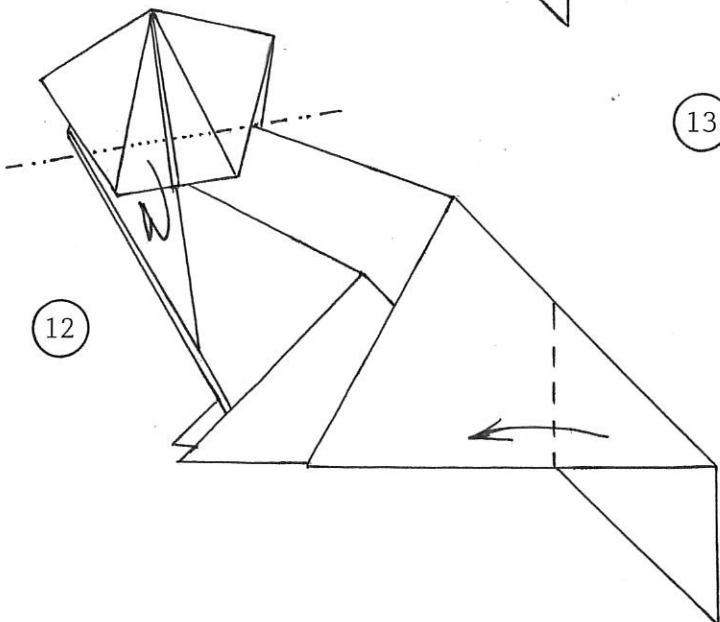

13

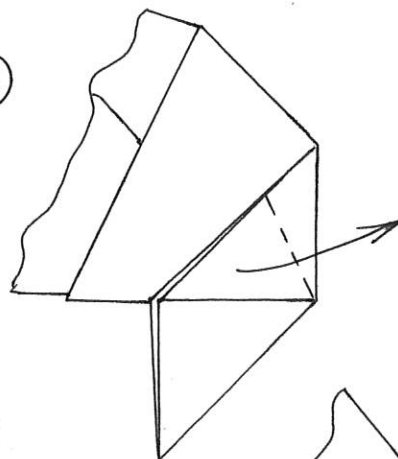

14

OPEN OUT

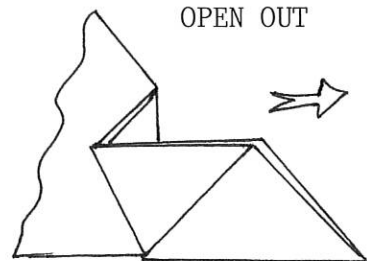

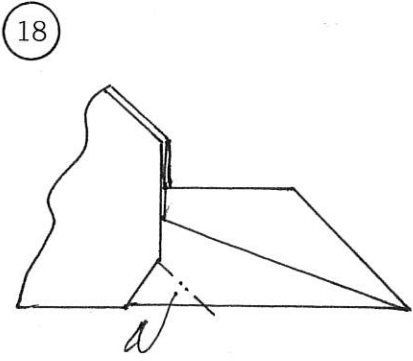
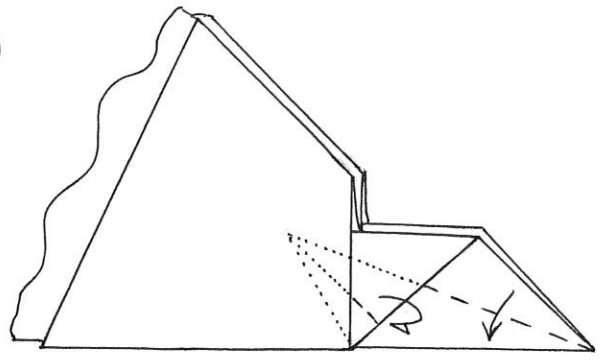
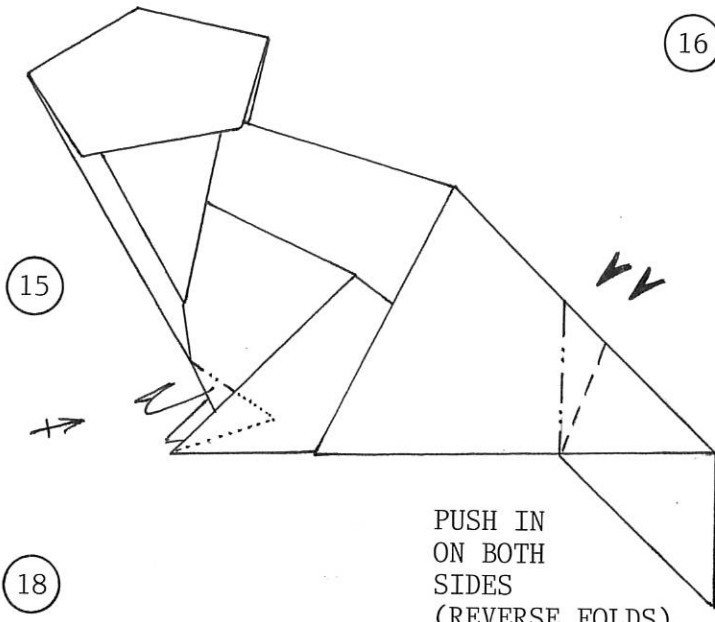

PUSH IN
ON BOTH
SIDES
(REVERSE FOLDS)

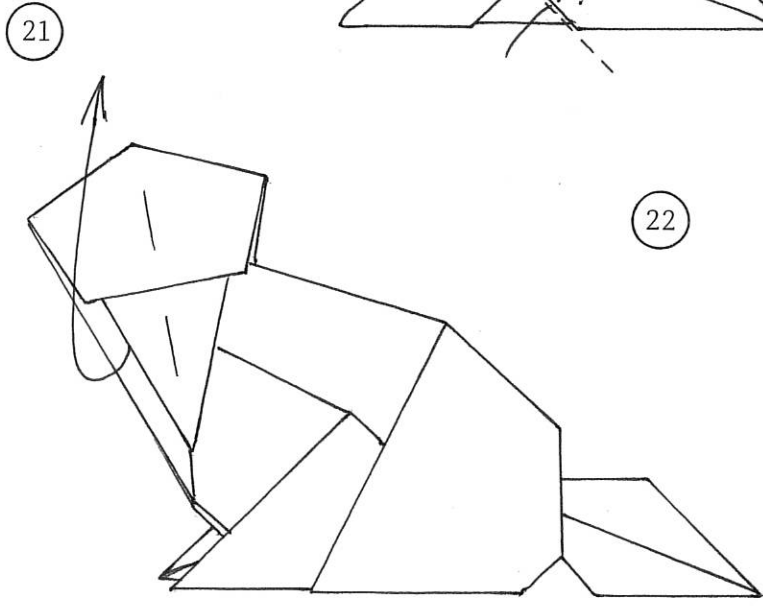
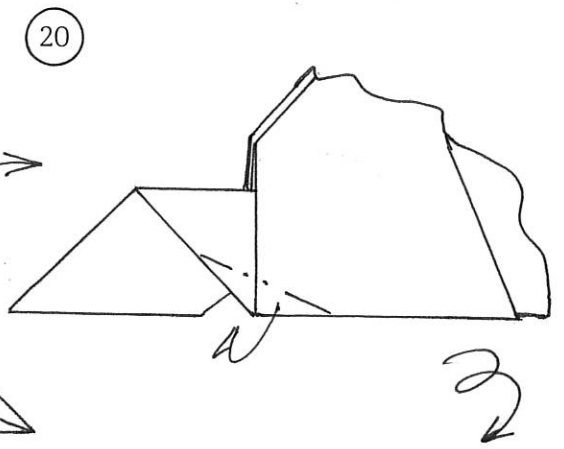
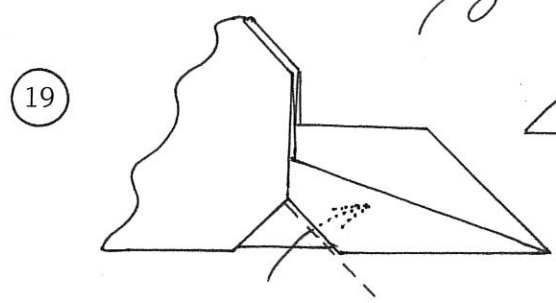
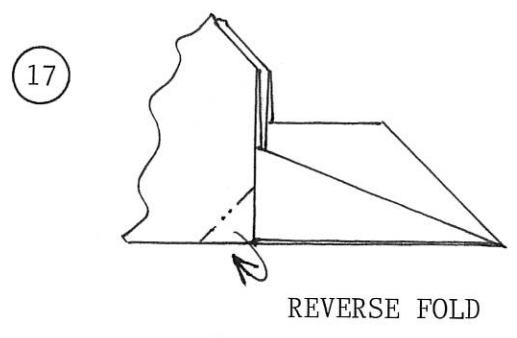

LIFT UP THE HEAD.
THE PAPER WILL NOT LIE FLAT.

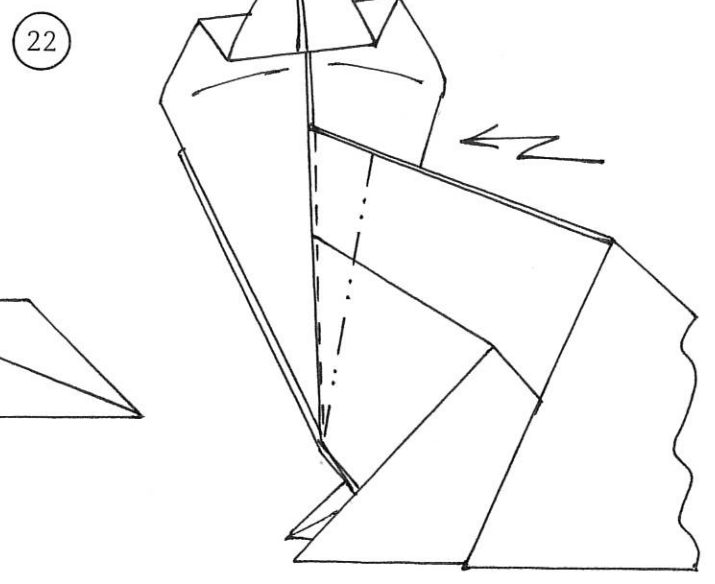

CRIMP ALL LAYERS TOGETHER

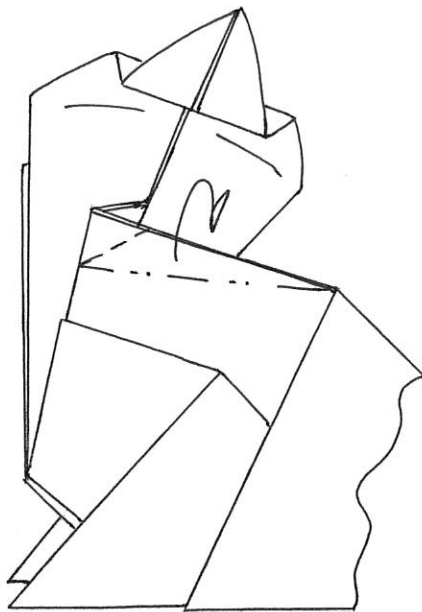

23

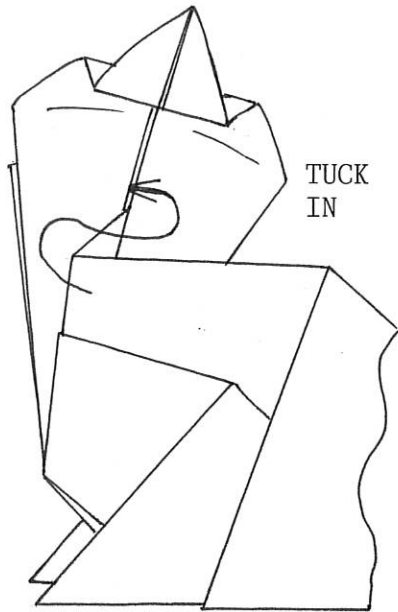

24

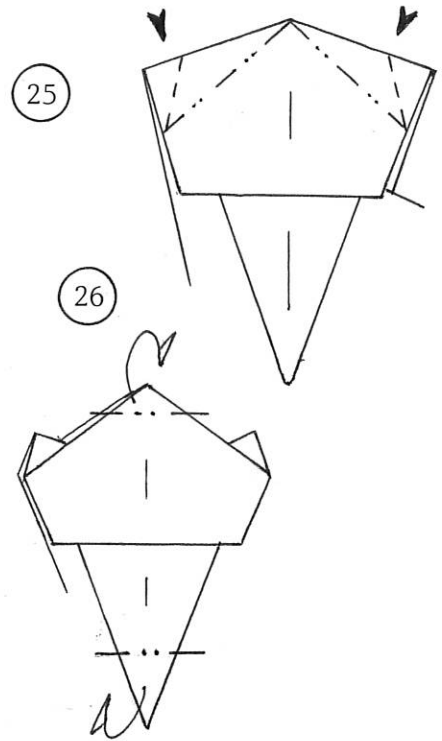

25

26

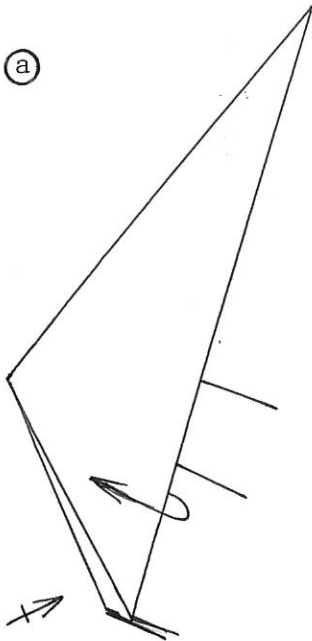

a

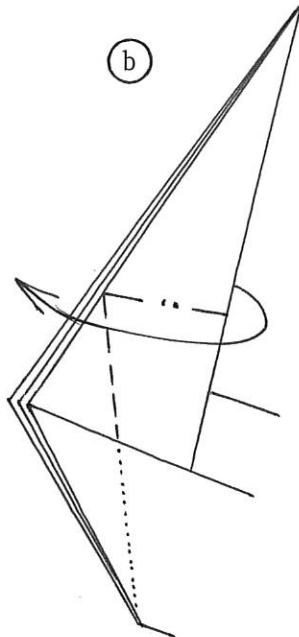

b

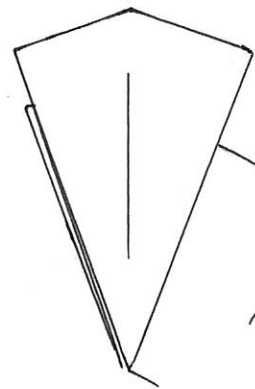

c

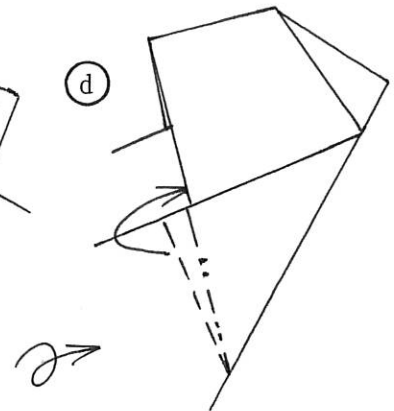

d

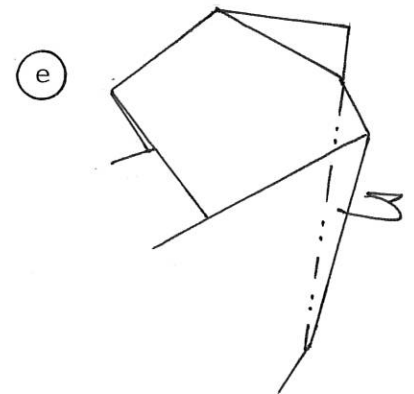

e

27

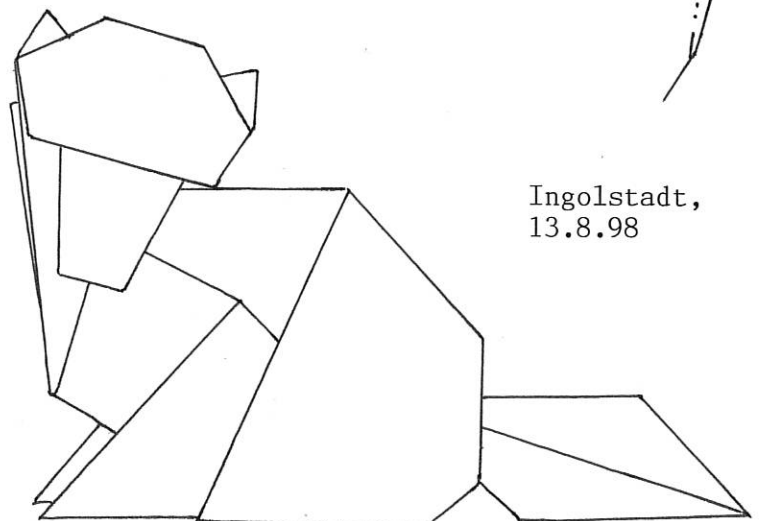

WITH PAPER COLOURED
ON ONE SIDE ONLY:

START WITH THE PAPER WHITE
SIDE UP AND FOLD THE WHOLE
MODEL. THEN UNFOLD HEAD TO
STEP 8 AND FOLLOW STEPS a TO c
ABOVE. STEPS d AND e ARE NEEDED
WHEN REINSTATING THE CRIMP IN
STEP 22.

THE RESULT SHOULD LOOK THE SAME.

Ingolstadt,
13.8.98